

# HIGH PERFORMANCE PIEZOELECTRIC ACTUATORS

CATALOG 2023/2024 – WAVELLING®  
WLG MOTORS RANGE

# 1. Table of contents

1.	Table of contents .....	1
2.	About Tekceleo .....	3
3.	Our solutions .....	4
4.	Motor characteristics .....	5
4.1.	Mechanical principles.....	5
4.2.	Control principles .....	6
5.	WLG-R SERIES.....	7
5.1.	WLG-75-R.....	8
5.1.1.	WLG-75-R SERIES Technical Specification .....	8
5.1.2.	WLG-75-R dimensions.....	9
5.1.3.	WLG-75-R AMAG dimensions.....	9
5.1.4.	WLG-75-R SERIES Mechanical Data .....	9
5.1.5.	WLG-75-R SERIES Connection.....	10
5.1.6.	WLG-75-R SERIES encoder output waveform .....	10
5.1.7.	WLG-75-R SERIES Performance .....	11
5.2.	WLG-30-R.....	12
5.2.1.	WLG-30-R SERIES TECHNICAL SPECIFICATION.....	12
5.2.2.	WLG-30-R SERIES dimensions .....	13
5.2.3.	WLG-30-R SERIES Mechanical Data .....	13
5.2.4.	WLG-30-R SERIES Connection.....	14
5.2.5.	WLG-30-R SERIES encoder output waveform .....	14
5.2.6.	WLG-30-R Performance .....	15
5.3.	WLG-20-R.....	16
5.3.1.	WLG-20-R SERIES Technical Specification .....	16
5.3.2.	WLG-20-R SERIES dimensions .....	17
5.3.3.	WLG-20-R SERIES Mechanical Data .....	17
5.3.4.	WLG-20-R SERIES Connection.....	18
5.3.5.	WLG-20-R SERIES encoder output waveform .....	18
5.3.6.	WLG-20-R SERIES Performance .....	19
6.	Controllers.....	20
6.1.	WLG-75-R Controller .....	21
6.1.1.	Technical Specifications .....	21
6.2.	WLG-20 /WLG-20-AMAG Controller.....	23
6.2.1.	Technical Specifications .....	23

6.3.	WLG-30 Controller.....	24
6.3.1.	Technical Specifications .....	24
6.4.	WLG-30-AMAG Controller.....	25
6.4.1.	Technical Specifications .....	25
7.	Evaluation kit .....	27
7.1.	STM32 Microcontroller.....	27
7.2.	WAVELLING® Demo software.....	27
8.	Accessories .....	28
8.1.	Cable matrix.....	28
8.2.	Electrical cable extensions .....	29

## 2. About Tekceleo

Tekceleo is a French manufacturer of piezoelectric actuators of high quality. Our know-how is based on more than 20 years of works and manufacturing in piezoelectrics mechatronics devices.

We are known for our ability to provide creative and practical solutions focused on our client use cases. Our offer focuses on two product lines: Micronice for aerosol generation actuator and Wavelling for ultrasonic motors.

Tekceleo's main market are pharmaceutical, medical, automation, measurement and aerospace industries. All our operations (design, manufacturing and marketing) are ISO 9001 certified. All our product are produced in our own facility in Mougins, South of France.

Our company is composed of a multidisciplinary team of engineers and physicists who have all the necessary tools to integrate the different technologies composing a product : mechanics, plastics, thermics, electronics and embedded software.

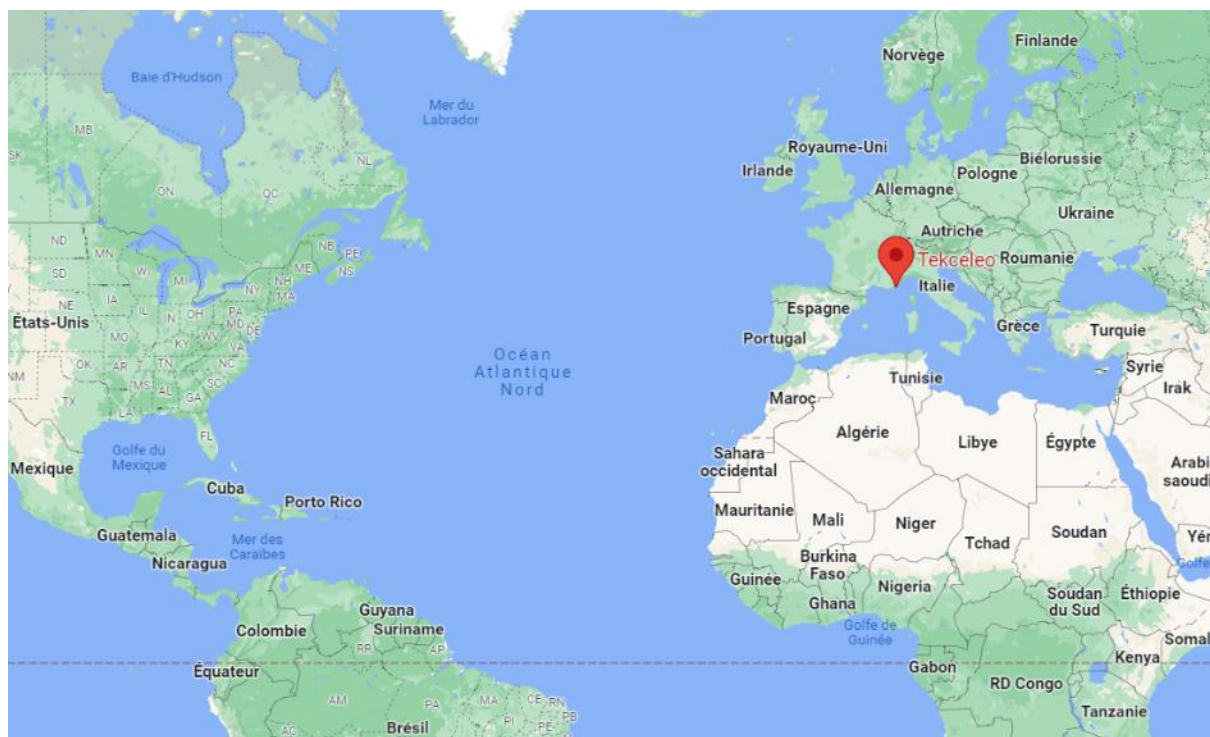

### 3. Our solutions



#### MANUFACTURING

Tekceleo brings its craftsmanship and know-how in manufacturing best of the line piezo actuators. Our flexible manufacturing line allows customization and high reactivity.

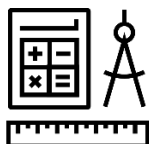

#### ENGINEERING

We offer more than 20 years of experience in innovation. Each customer has different projects, expectations and goals. We can adjust our solution to fit your design. Our team of engineers brings support and consulting to add value to your project.



#### PARTNERSHIP AND INTEGRATION

Tekceleo is here to help you get started with our technology. We help you throughout your integration process with our engineering team as a partner. We ensure confidentiality and support to our customer. We can also work as system integrators and technology consultants if needed.



#### SUPPORT FROM EVALUATION TO PRODUCTION

Our value proposition is based on a complete support for our customers and partners in their industrialization process : design, prototyping, characterization, production and optimization. We help you to get through all your innovation cycle.

## 4. Motor characteristics

### 4.1. Mechanical principles

Based on a progressive wave actuator technology coupled with integrated control sensors, Tekceleo's motors are among the most efficient on the market in terms of torque-to-weight ratio, ease of control in "Direct Drive", combining speed, precision and robustness.

The flexibility of our WAVELLING® technology enables our motor to achieve a wide range of performances and uses, ranging from nominal speeds of a few RPM to 600 RPM depending on the type of motors, all without a reducer (no backlash or jerks). Our range of piezo motors is one of the best in class in terms of low speed/high torque ratio, with a unique expertise in very small rotary piezo actuator.

Our WAVELLING® technology is based on the Travelling Wave Ultrasonic Motor design which works based on the interaction of three key elements :

- A piezoelectric ceramic with segmented electrodes ;
- A vibratory stator ;
- A rotor pressed on the comb-tooth shaped stator.

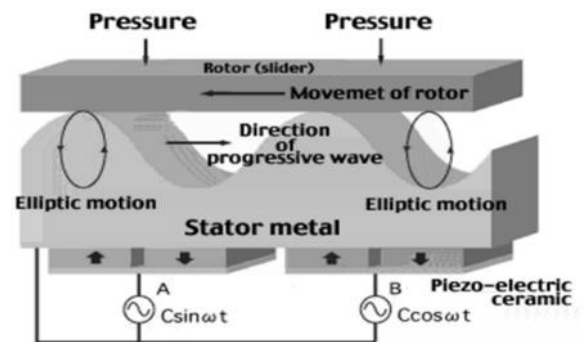

Our motors are pure mechanical actuator, which allows for actuation without any electromagnetic fields or ferromagnetic materials. The rotor is moved by a progressive wave of a vibrating stator by multiple continuous contact point. This provides a very good compromise between size, power and precision.

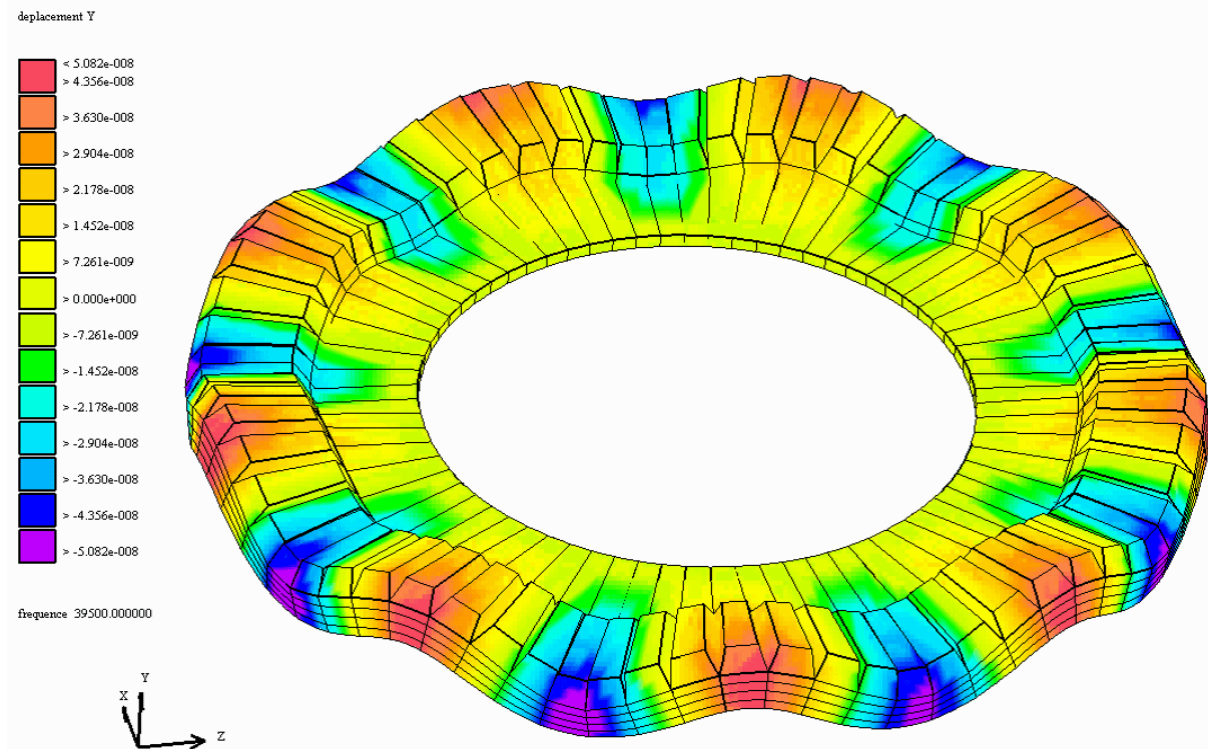

**SIMULATION OF TRAVELLING WAVE MODULATION ON A WLG-75 STATOR**



## 4.2. Control principles

In order to control the linear or angular position, velocity and acceleration, our piezo motor uses a closed loop control mechanism. The closed loop control system measures the position and then converts it into an electrical signal with our embedded encoder technology. As a result, Tekceleo’s WAVELLING® piezo motors are able to have a speed setpoint as well as a position setpoint. Following signals are used to control the motor :

- For the rotative-direction change of CW-CCW, and a Stop of the motor, two signals of a TTL level are required.
- For speed change, an analog signal of DC 0 [V] - 3.3 [V] is required.

In order to stabilize the speed of a motor, an internal closed loop control is integrated in the controllers of the motors. Speed control of the motor is defined by its drive frequency.

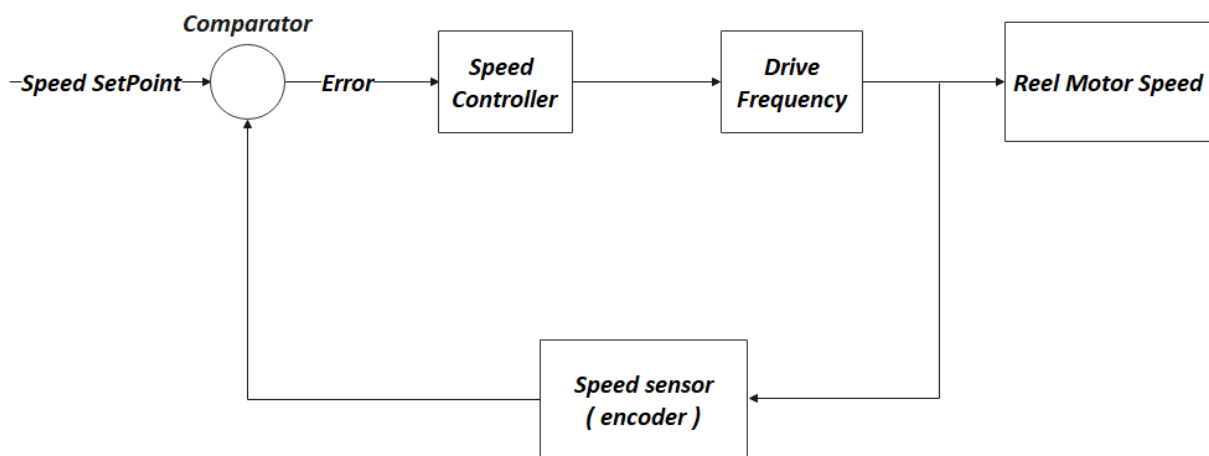

### INTERNAL CLOSED LOOP VELOCITY PRINCIPLE THAT IS INTEGRATED IN THE CONTROLLER ITSELF

Position of the motor is controllable by using the encoder signals. To achieve smooth position control and optimize precision, customer can use a proportional control. It allows to correct the controlled variable and proportionally correct the difference between desired value (e.g. position setpoint) and the measured value (e.g. real motor position).

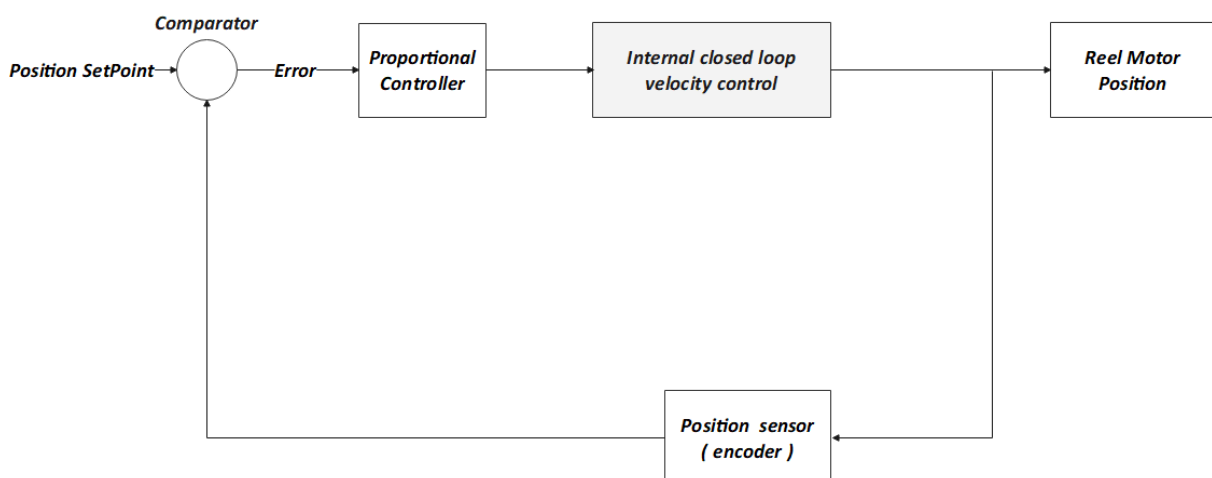

### SIMULATION OF TRAVELLING WAVE MODULATION ON A WLG-75 STATOR

## 5. WLG-R SERIES



Our line of piezoelectric motors, based on our unique WAVELLING® know-how, ranges from 20mm (for miniature motors) to 75mm diameters. TEKCELEO offers the following actuators, all of which allow non-magnetic configurations for MRI environments:

- WLG-75-R : Diameter 75mm (external casing diameter : 80,5 mm)
- WLG-30-R : Diameter 30 mm (external casing diameter : 33,9 mm)
- WLG-20-R : Diameter 20 mm (external casing diameter : 23,9 mm)

	Rated Power	Max Torque	Rated Torque	Max speed	Min Speed	Max standard Encoder precision	Non-magnetic version
WLG-75-R	15W	1,5 N.m	0,75 N.m	250 RPM	1 RPM	0,0156°	Yes
WLG-30-R	1.3W	100 mN.m	75 mN.m	250 RPM	1 RPM	0,0450°	Yes
WLG-20-R	0.55W	30 mN.m	20 mN.m	380 RPM	1 RPM	0,0625°	Yes



## 5.1. WLG-75-R

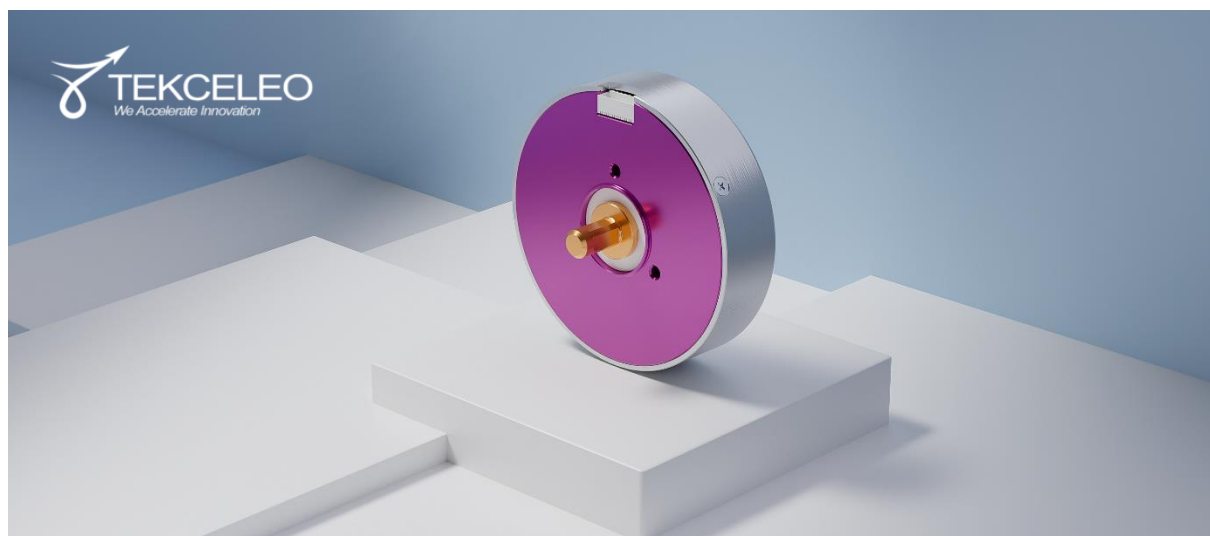

### 5.1.1. WLG-75-R SERIES Technical Specification

		WLG-75-R	WLG-75-R AMAG (Non-Magnetic)
<b>Performances</b>	No Load Speed	250 RPM	250 RPM
	Nominal Speed	190 RPM	190 RPM
	Max Torque	1.5 N.m	1.5 N.m
	Nominal Torque	0.75 N.m	0.75 N.m
	Holding Torque	1.87 N.m	1.87 N.m
<b>Precision</b>	Built-in encoder	Yes, optical with quadrature output	Yes, optical with quadrature output
	Max Encoder Resolution	0,0156° / 273 µr	0,0156° / 273 µr
	Possible Max encoder Resolution (custom)	0,0039° / 68 µr	0,0039° / 68 µr
<b>Operations</b>	Operating Voltage	24 VDC	24 VDC
	Maximal Power Consumption	24 VDC / 3.2 A	24 VDC / 3.2 A
	Weight	282 g	282 g
	Operating Temperature	0°C – 45°C	0°C – 45°C
	Connector	Molex ref. 87438-0843	Molex ref. 87438-0843

### 5.1.2.WLG-75-R dimensions

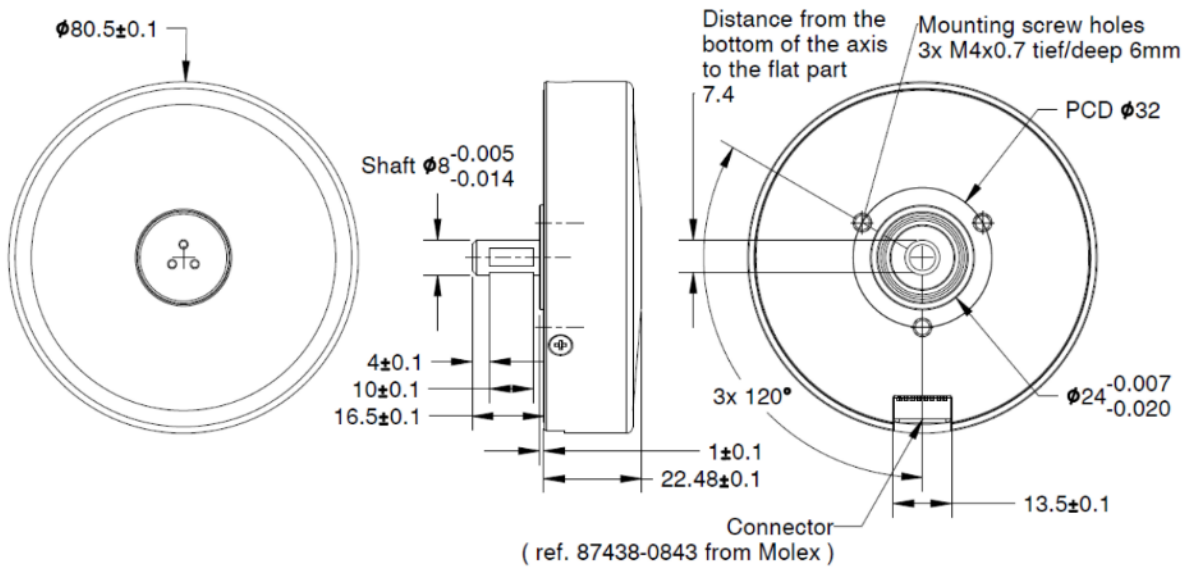

### 5.1.3.WLG-75-R AMAG dimensions

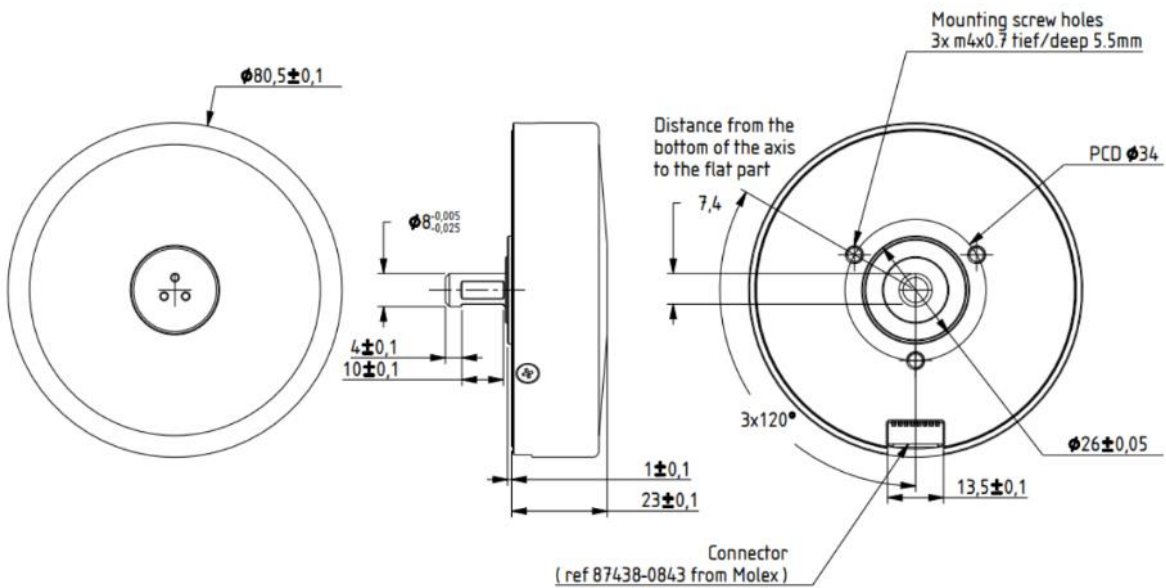

### 5.1.4.WLG-75-R SERIES Mechanical Data

	WLG-75-R	WLG-75-R AMAG (non-magnetic)
Max Radial Load	10 N	10 N
Max Axial Load Dynamics	10 N	10 N
Max Force for Press Fits	120 N	120 N
Shaft Concentricity	$\pm 0,04$ mm	$\pm 0,04$ mm

### 5.1.5.WLG-75-R SERIES Connection

Pin	Input/Output	Specification
1	Input	Sin Wave
2	-	GND
3	Input	Cos Wave
4	Input	5 Vdc for encoder power supply
5	-	GND
6	Output	Incremental encoder signal A
7	Output	Incremental encoder signal B
8	Output	Incremental encoder index

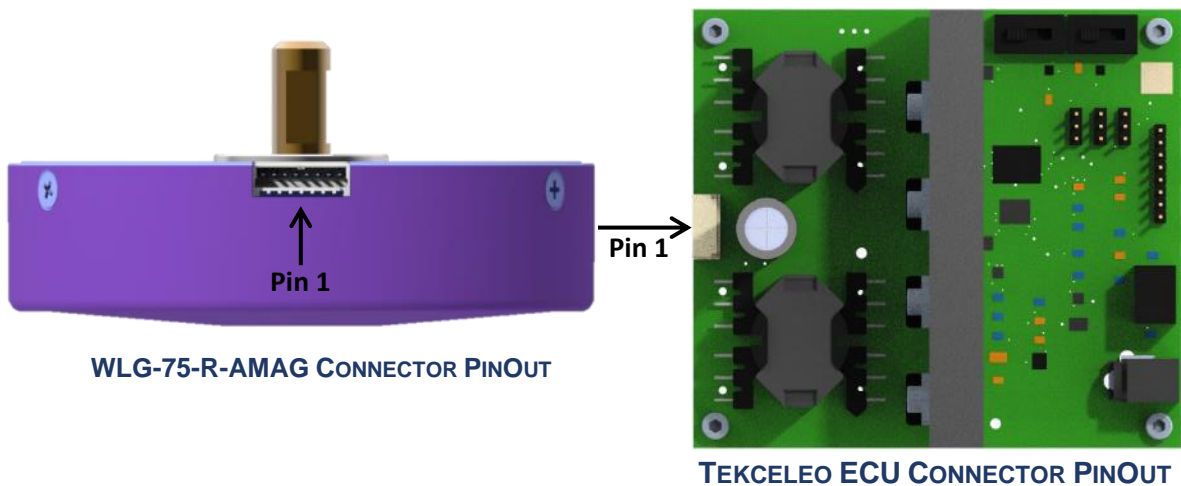

### 5.1.6.WLG-75-R SERIES encoder output waveform

#### Output waveform

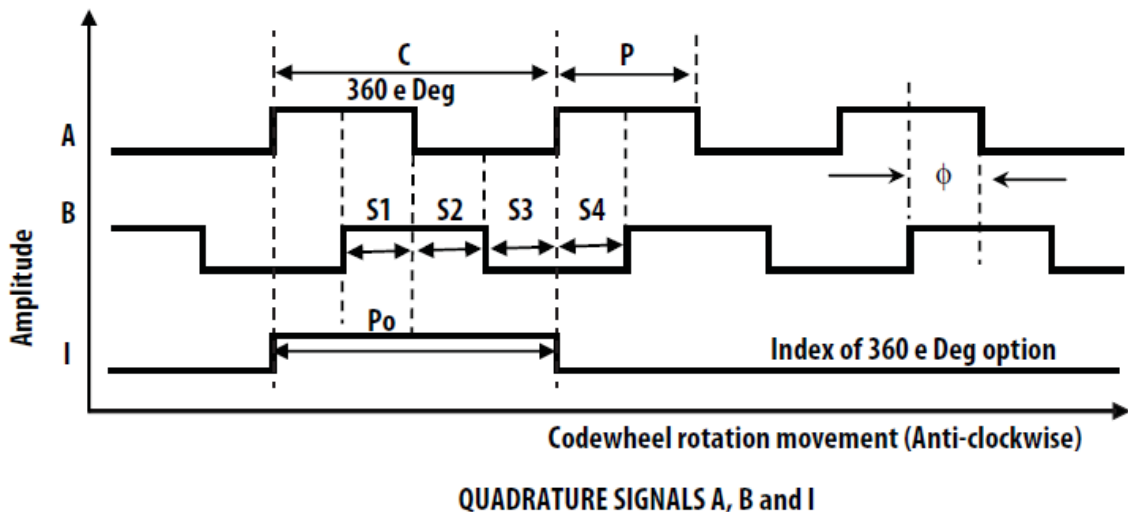

### 5.1.7.WLG-75-R SERIES Performance

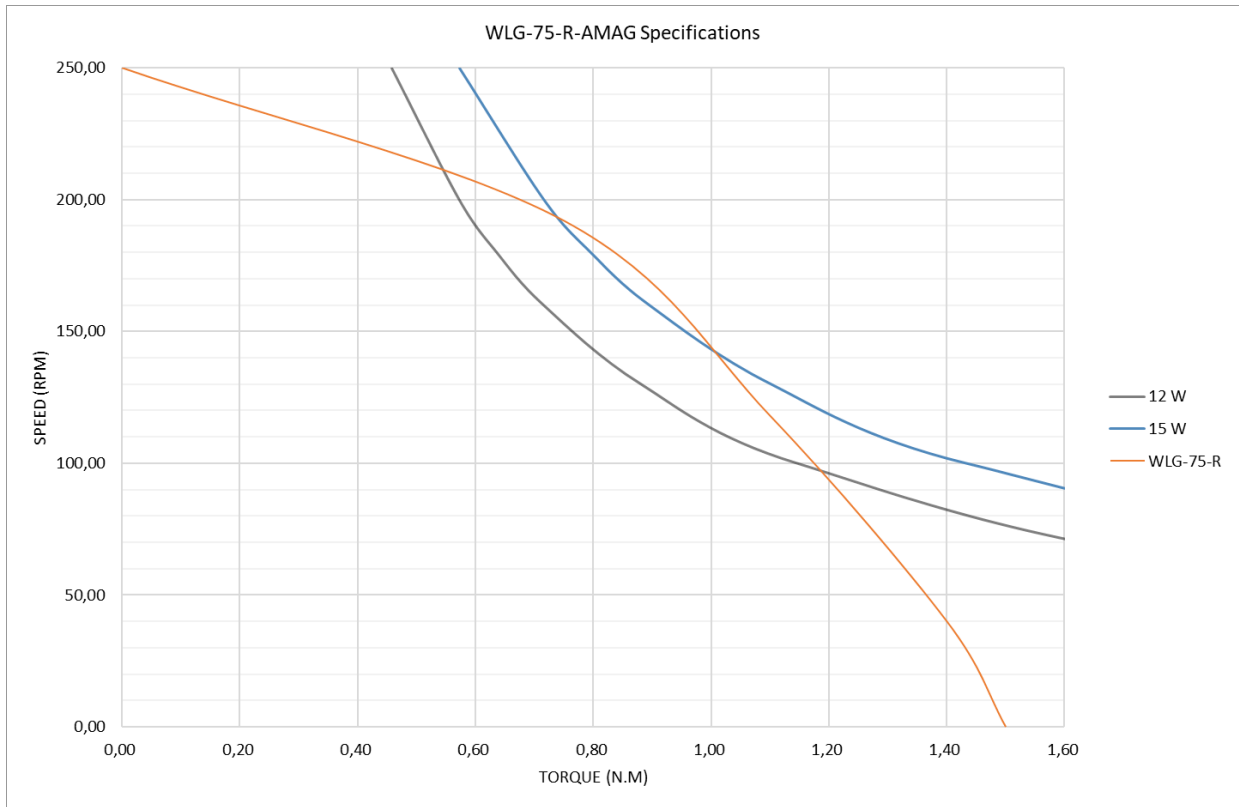

## 5.2. WLG-30-R

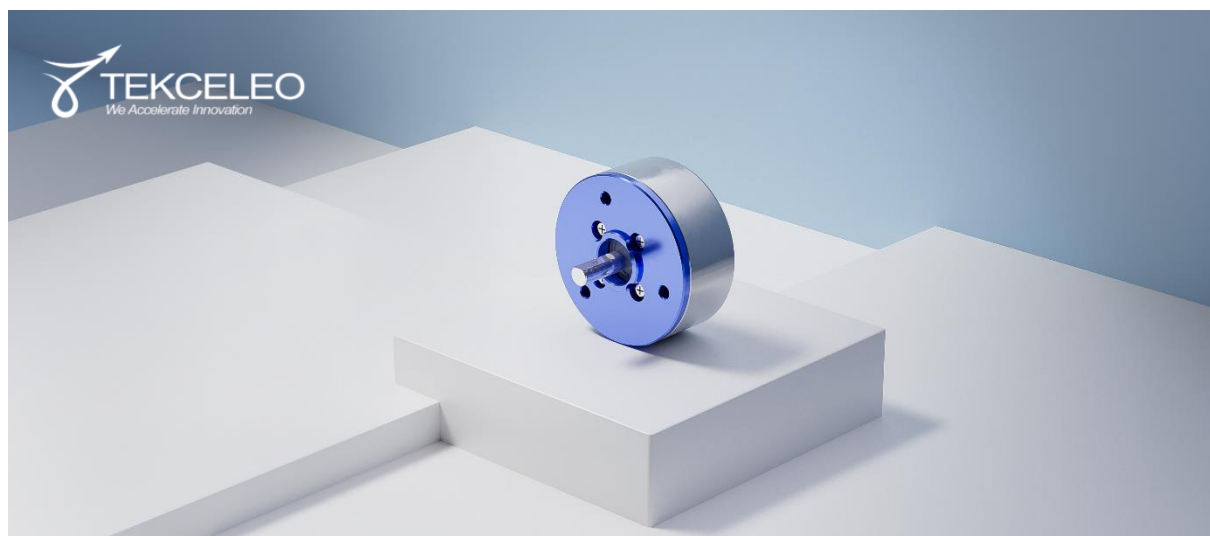

### 5.2.1. WLG-30-R SERIES TECHNICAL SPECIFICATION

		WLG-30-R	WLG-30-R AMAG (Non-Magnetic)
<b>Performances</b>	No Load Speed	250 RPM	250 RPM
	Nominal Speed	165 RPM	165 RPM
	Max Torque	100 mN.m	100 mN.m
	Nominal Torque	75 mN.m	75 mN.m
	Holding Torque	125 mN.m	125 mN.m
<b>Precision</b>	Built-in encoder	Yes, optical with quadrature output	Yes, optical with quadrature output
	Max Encoder Resolution	0,0450° / 789 µr	0,0450° / 789 µr
	Possible Max encoder Resolution (custom)	0,0104° / 181 µr	0,0104° / 181 µr
<b>Operations</b>	Operating Voltage	7.5 VDC	7.5 VDC
	Maximal Power Consumption	7.5 VDC / 1.35 A	7.5 VDC / 1.35 A
	Weight	37,7 g	37,7 g
	Operating Temperature	0°C – 60°C	0°C – 60°C
	Connector	JST - SHR-08V-S-B	JST - SHR-08V-S-B

### 5.2.2.WLG-30-R SERIES dimensions

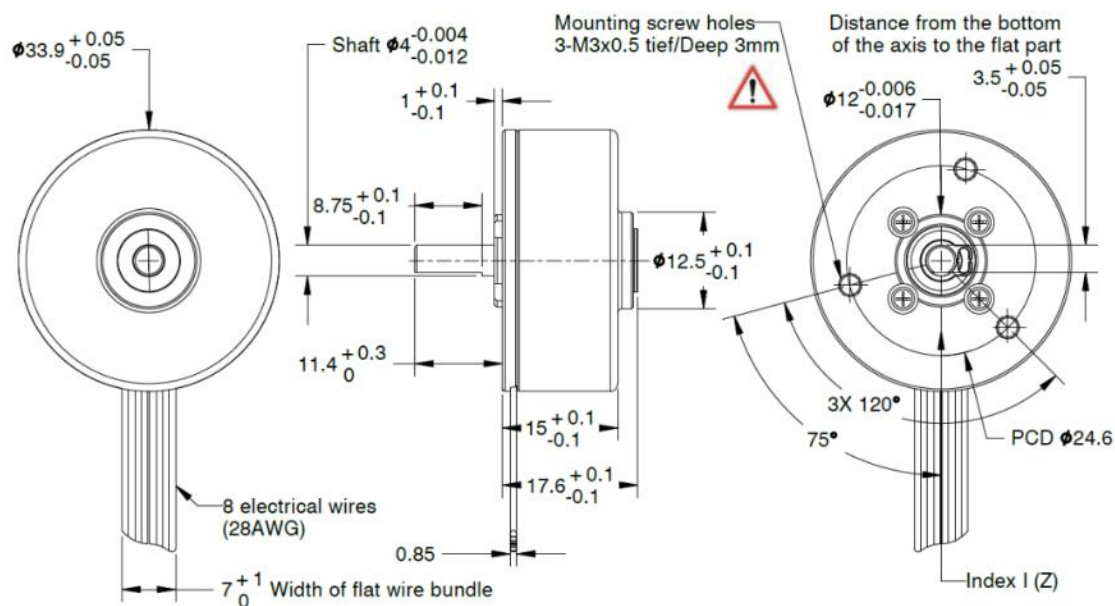

### 5.2.3.WLG-30-R SERIES Mechanical Data

	WLG-30-R	WLG-30-R AMAG (non-magnetic)
Max Radial Load	10 N	10 N
Max Axial Load Dynamics	2 N	2 N
Max Force for Press Fits	80 N	80 N
Shaft Concentricity	$\pm 0,075$ mm	$\pm 0,075$ mm



### 5.2.4.WLG-30-R SERIES Connection

Pin	Input/Output	Specification
1	Input	Sin Wave
2	-	GND
3	Input	Cos Wave
4	Input	5 Vdc for encoder power supply
5	-	GND
6	Output	Incremental encoder signal A
7	Output	Incremental encoder signal B
8	Output	Incremental encoder index

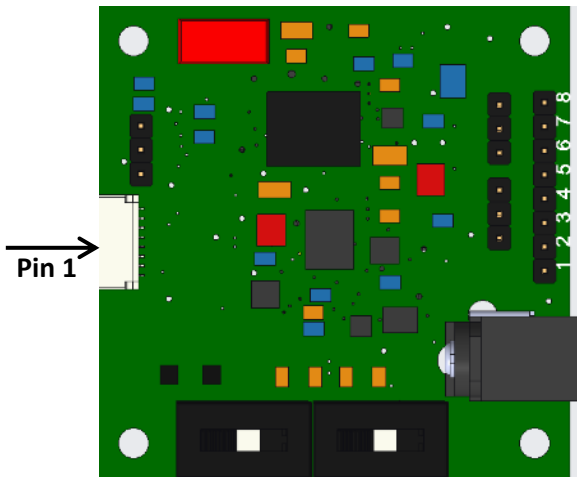
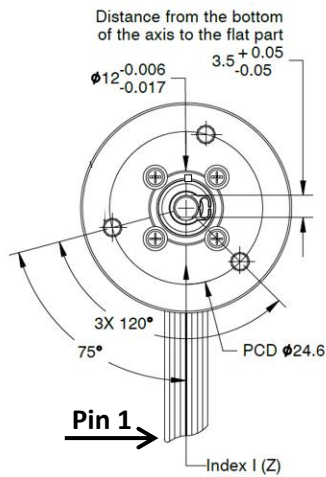

### 5.2.5.WLG-30-R SERIES encoder output waveform

#### Output waveform

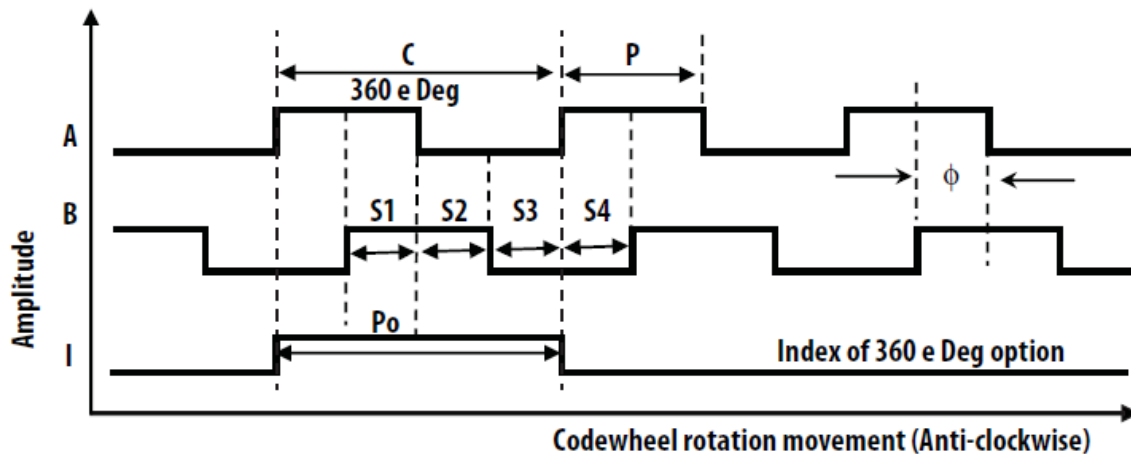

QUADRATURE SIGNALS A, B and I

### 5.2.6.WLG-30-R Performance

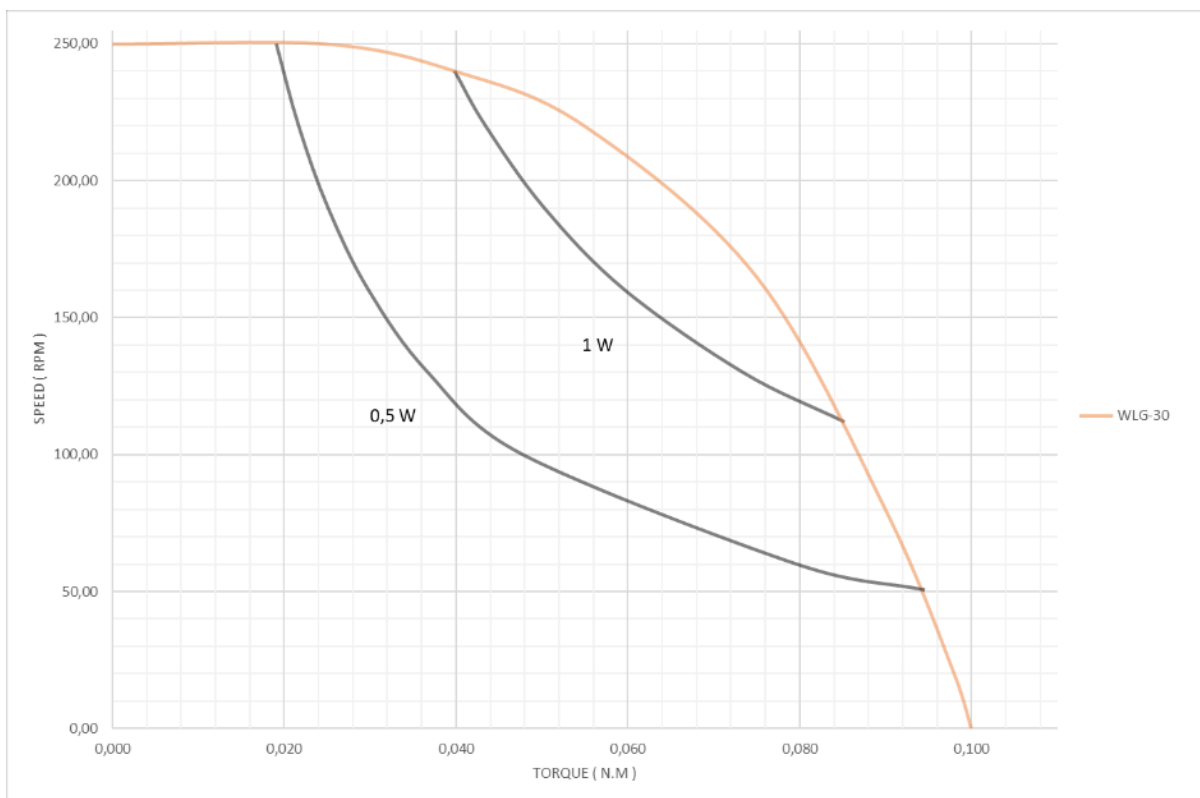

## 5.3. WLG-20-R

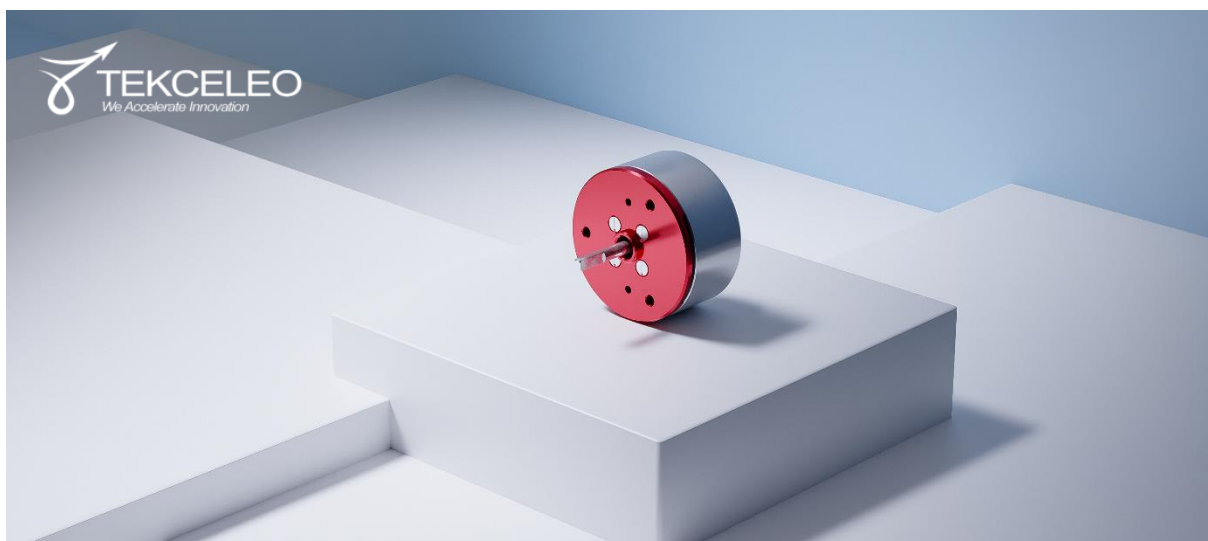

### 5.3.1.WLG-20-R SERIES Technical Specification

		WLG-20-R	WLG-20-R AMAG (Non-Magnetic)
<b>Performances</b>	No Load Speed	380 RPM	380 RPM
	Nominal Speed	265 RPM	265 RPM
	Max Torque	30 mN.m	30 mN.m
	Nominal Torque	20 mN.m	20 mN.m
	Holding Torque	40 mN.m	40 mN.m
<b>Precision</b>	Built-in encoder	Yes, optical with quadrature output	Yes, optical with quadrature output
	Encoder Resolution	0,0625° / 1091 µr	0,0625° / 1091 µr
	Possible Max encoder Resolution (custom)	0,0156° / 273 µr	0,0156° / 273 µr
<b>Operations</b>	Operating Voltage	9 VDC	9 VDC
	Maximal Power Consumption	9 VDC/0.8 A	9 VDC/0.8 A
	Weight	14 g	14 g
	Operating Temperature	0°C – 45°C	0°C – 45°C
	Connector	JST - SHR-08V-S-B	JST - SHR-08V-S-B

### 5.3.2.WLG-20-R SERIES dimensions

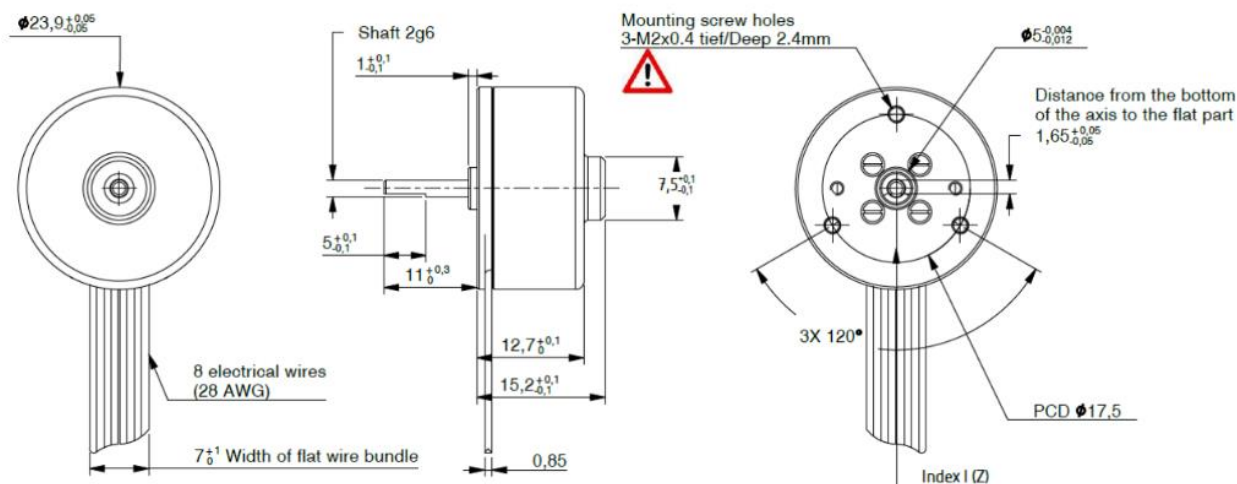

### 5.3.3.WLG-20-R SERIES Mechanical Data

	WLG-30-R	WLG-30-R AMAG (non-magnetic)
Max Radial Load	5 N	5 N
Max Axial Load Dynamics	1 N	1 N
Max Force for Press Fits	18 N	18 N
Shaft Concentricity	$\pm 0,2$ mm	$\pm 0,2$ mm

### 5.3.4.WLG-20-R SERIES Connection

Pin	Input/Output	Specification
1	Input	Sin Wave
2	-	GND
3	Input	Cos Wave
4	Input	5 Vdc for encoder power supply
5	-	GND
6	Output	Incremental encoder signal A
7	Output	Incremental encoder signal B
8	Output	Incremental encoder index

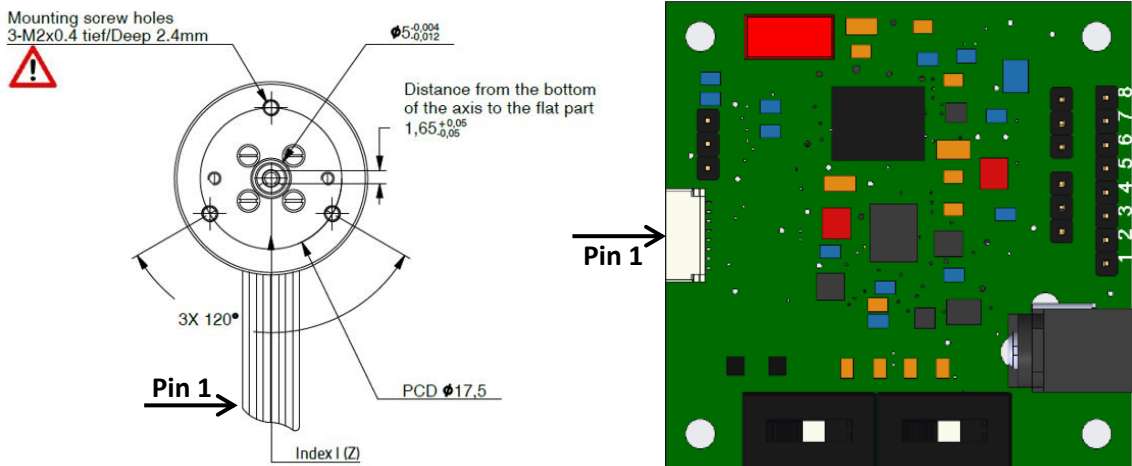

### 5.3.5.WLG-20-R SERIES encoder output waveform

#### Output waveform

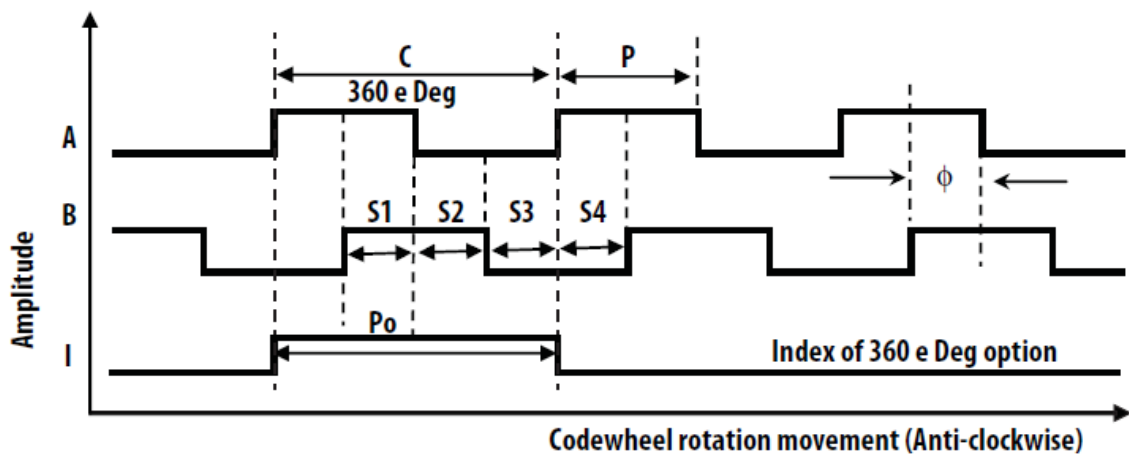

QUADRATURE SIGNALS A, B and I

### 5.3.6.WLG-20-R SERIES Performance

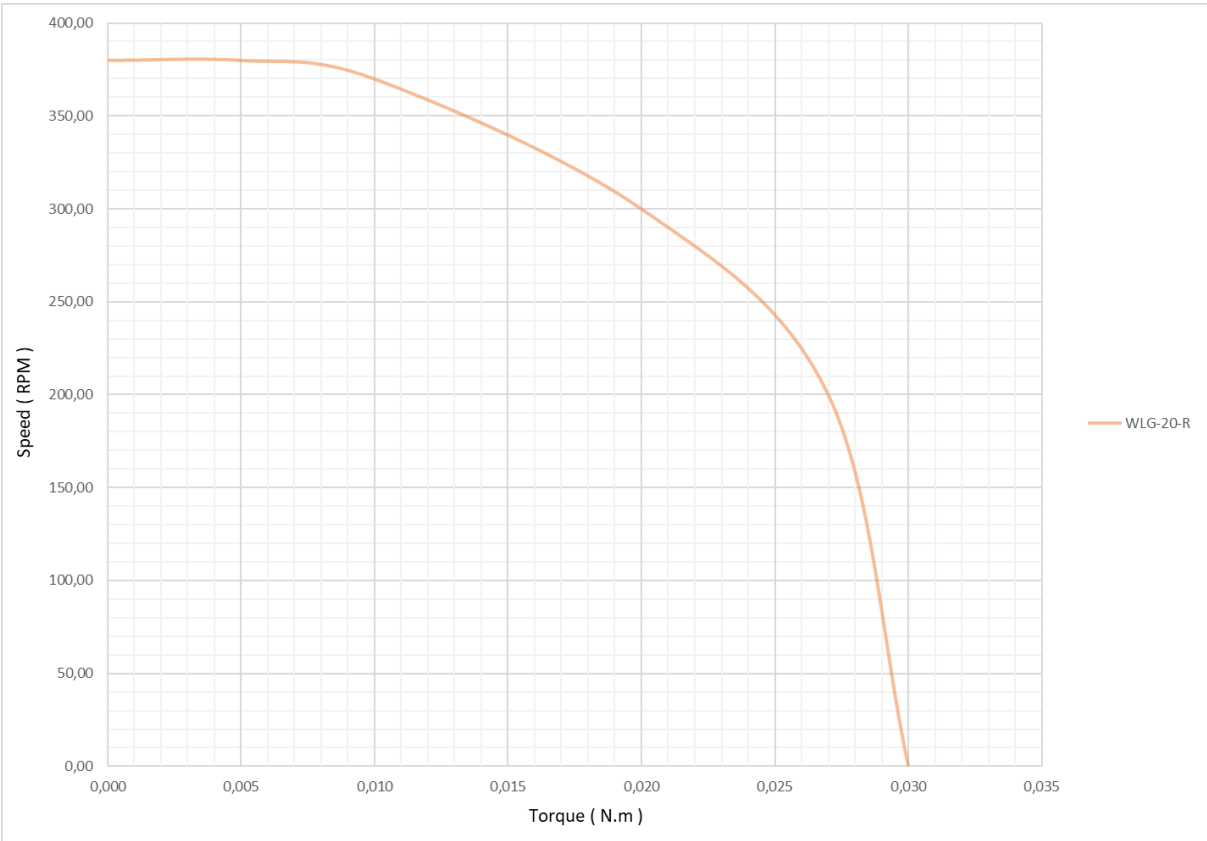



## 6. Controllers



**WLG-75-R CONTROLLER**



**WLG-20 AND 30-R CONTROLLER**

Tekceleo offers two types of controllers depending on the size of the motor. These controllers can be shared through license agreement for customers who want to incorporate the electronics into their own systems.

All our controller can directly control continuous movement with switches. For precise motion control it is necessary to use a micro-controller connected to the controller.

In our evaluation kit we offer specific STM32 microcontroller with embedded demo software for easily handle our motors. Software can be shared and/or customized on demand.

## 6.1. WLG-75-R Controller

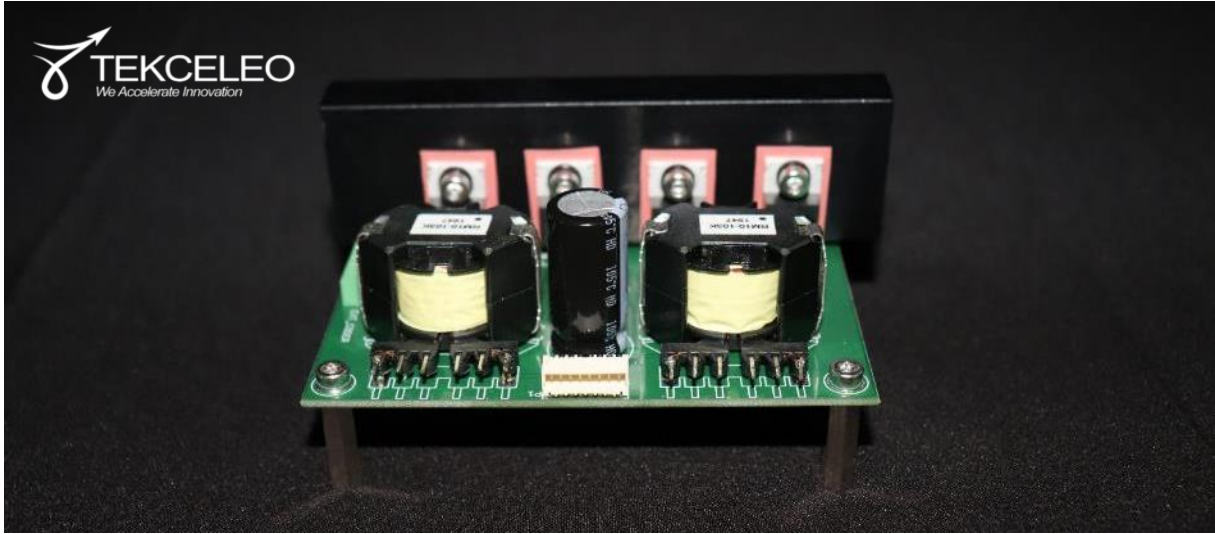

### 6.1.1. Technical Specifications

Type	Value
Power Source Voltage	DC24 [V] $\pm$ 0.5 [V]
Oscillation Waveform	Pseudo Sine Wave
Oscillation Frequency	35 [KHz] $\sim$ 45 [KHz]
Speed Adjustment Method	Frequency modulation
Motor Drive Voltage	220 [Vrms]
Consumption Current	DC24V : 3.0 [A]
Storage Temperature	0 [°C] $\sim$ +45 [°C]
Working Temperature	0 [°C] $\sim$ +45 [°C]
Start-Stop Control	On Off digital control TTL level signal (0 or 3.3 VDC)
Starting/stopping Response	< 500 $\mu$ s
Speed change response time	< 50 ms
No-load Adjustable Speed Range	5 [rpm] $\sim$ 175 [rpm]
Speed Setting External Voltage	DC 0[V] $\sim$ 3.3 [V]
Weight	180 [g]
Outline Size	Vertical x Horizontal x Height : 100 [mm] x 90 [mm] x 34 [mm]

**Molex pico-SPOX 8 pins female connector Motor output**

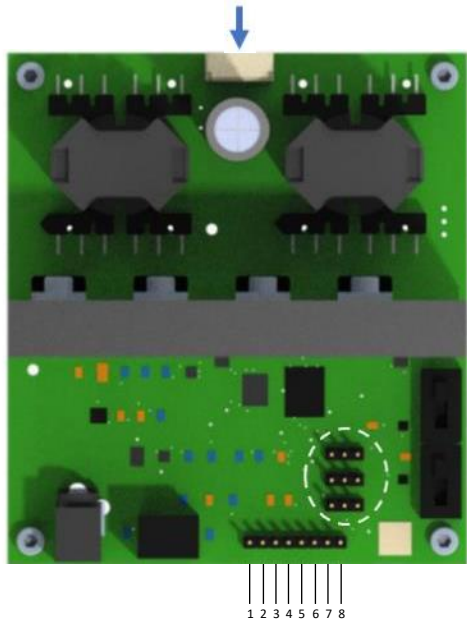

PIN	I/O	Specifications
1	I	Speed control using analog voltage 0-3.3 VDC
2	-	Ground
3	I	ON/OFF digital control TTL level signal (0 or 3.3 VDC)
4	I	CW/CCW digital control TTL level signal (0 or 3.3 VDC)
5	O	Incremental encoder signal A
6	O	Incremental encoder signal B
7	O	Incremental encoder index
8	-	Not used

## 6.2. WLG-20 /WLG-20-AMAG Controller



### 6.2.1. Technical Specifications

Type	Value
Power Source Voltage	DC9 [V] ±0.5 [V]
Oscillation Waveform	Pseudo Sine Wave
Oscillation Frequency	35 [KHz] ~ 50 [KHz]
Speed Adjustment Method	Closed loop Frequency Modulation Method using integrated encoder information
Motor Drive Voltage	180 [Vrms]
Consumption Current	DC9V : 1.0 [A]
Storage Temperature	0 [°C] ~ +45 [°C]
Working Temperature	0 [°C] ~ +45 [°C]
Start-Stop Control	On Off digital control TTL level signal (0 or 3.3 VDC)
Starting/stopping Response	< 500 µs
Speed change response time	< 50 ms
No-load Adjustable Speed Range	30 [rpm] ~ 380 [rpm]
Speed Setting External Voltage	DC 0[V] ~ 3.3 [V]
Weight	47 [g]
Outline Size	Vertical x Horizontal x Height : 50 [mm] x 50 [mm] x 26 [mm]

## 6.3. WLG-30 Controller



### 6.3.1. Technical Specifications

Type	Value
Power Source Voltage	DC7,5 [V] ±0.5 [V]
Oscillation Waveform	Pseudo Sine Wave
Oscillation Frequency	44 [KHz] ~ 53 [KHz]
Speed Adjustment Method	Closed loop Frequency Modulation Method using integrated encoder information
Motor Drive Voltage	115 [Vrms]
Consumption Current	DC7,5V : 1.5 [A]
Storage Temperature	0 [°C] ~ +45 [°C]
Working Temperature	0 [°C] ~ +45 [°C]
Start-Stop Control	On Off digital control TTL level signal (0 or 3.3 VDC)
Starting/stopping Response	< 500 µs
Speed change response time	< 50 ms
No-load Adjustable Speed Range	30 [rpm] ~ 250 [rpm]
Speed Setting External Voltage	DC 0[V] ~ 3.3 [V]
Weight	47 [g]
Outline Size	Vertical x Horizontal x Height : 50 [mm] x 50 [mm] x 26 [mm]



## 6.4. WLG-30-AMAG Controller

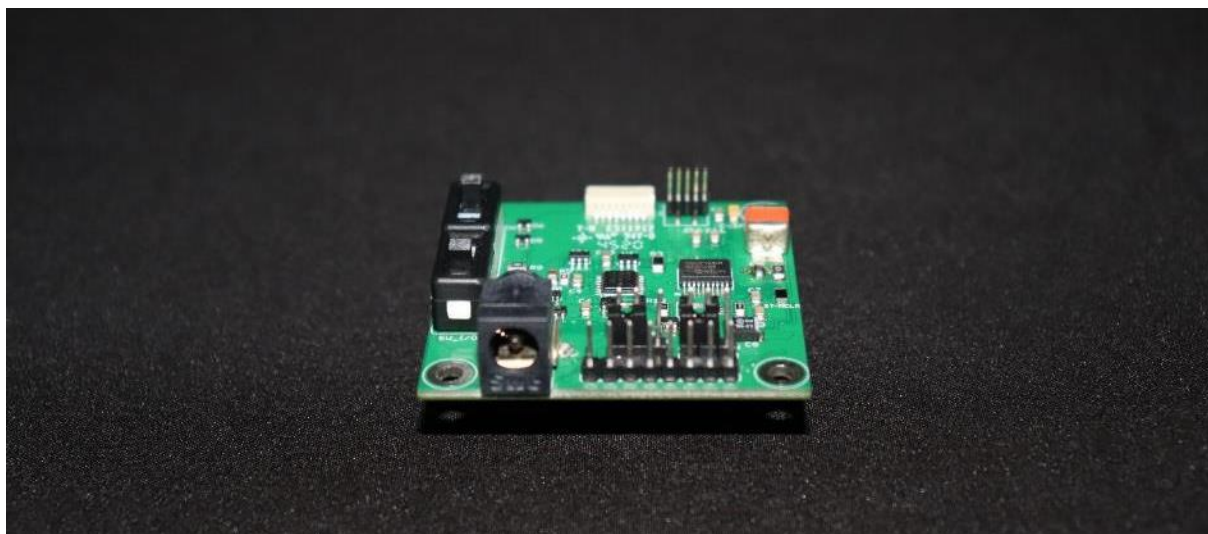

### 6.4.1. Technical Specifications

Type	Value
Power Source Voltage	DC7,5 [V] ±0.5 [V]
Oscillation Waveform	Pseudo Sine Wave
Oscillation Frequency	48 [KHz] ~ 60 [KHz]
Speed Adjustment Method	Closed loop Frequency Modulation Method using integrated encoder information
Motor Drive Voltage	115 [Vrms]
Consumption Current	DC7,5V : 1.5 [A]
Storage Temperature	0 [°C] ~ +45 [°C]
Working Temperature	0 [°C] ~ +45 [°C]
Start-Stop Control	On Off digital control TTL level signal (0 or 3.3 VDC)
Starting/stopping Response	< 500 µs
Speed change response time	< 50 ms
No-load Adjustable Speed Range	30 [rpm] ~ 250 [rpm]
Speed Setting External Voltage	DC 0[V] ~ 3.3 [V]
Weight	47 [g]
Outline Size	Vertical x Horizontal x Height : 50 [mm] x 50 [mm] x 26 [mm]



**Molex pico-SPOX 8 pins female connector Motor output**

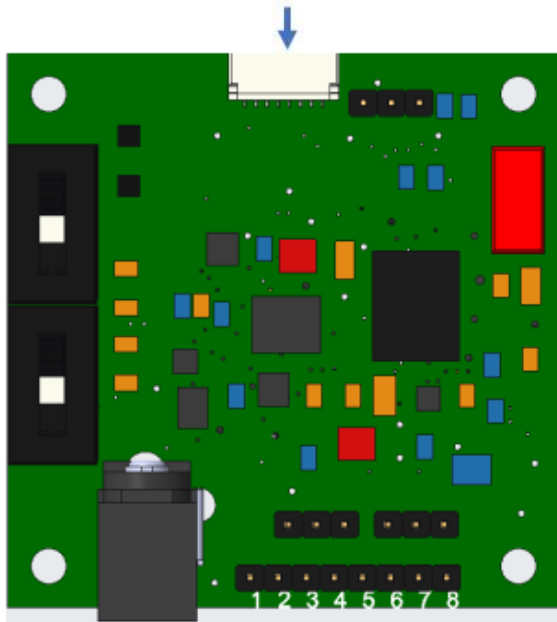

PIN	I/O	Specifications
1	I	Speed control using analog voltage 0-3.3 VDC
2	-	Ground
3	I	ON/OFF digital control TTL level signal (0 or 3.3 VDC)
4	I	CW/CCW digital control TTL level signal (0 or 3.3 VDC)
5	O	Incremental encoder signal A
6	O	Incremental encoder signal B
7	O	Incremental encoder index
8	-	Not used

## 7. Evaluation kit

Tekceleo offers evaluation/starter kit in order to easily get started with WAVELLING® motor technology. These kits are available with all our range of motor, standard and non-magnetic. They are delivered with the following items :

- One motor ;
- One controller and its power supply ;
- One STM32 Microcontroller ;
- Free demo software to get started ;
- A heat dissipation plate ;

Evaluation kit are made to learn how to handle our motor and comes with technical support. Our customer can always summon a technical meeting to discuss how to control and set up our motor.

### 7.1. STM32 Microcontroller

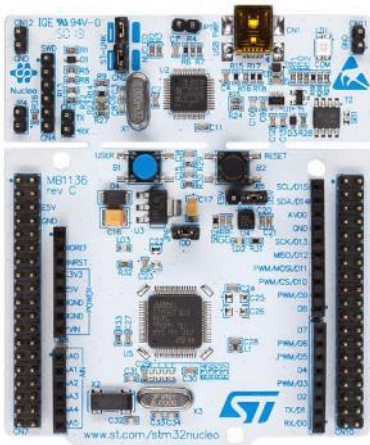

For easy evaluation and test we provide a simple evaluation microcontroller card. Just connect the board to the controller PIN using this guide :

- Nucleo : A2 / Piezo Driver : Pin 1
- Nucleo : GND / Piezo Driver : Pin 2
- Nucleo : A1 / Piezo Driver : Pin 3
- Nucleo : A0 / Piezo Driver : Pin 4
- Nucleo : D2 / Piezo Driver : Pin 5
- Nucleo : D3 / Piezo Driver : Pin 6
- Nucleo : D4 / Piezo Driver : Pin 7

***Power supply via USB VBUS or external source.***

The delivered STM32 of the evaluation kit directly contain a demo software for easily handling our WAVELLING® motor.

### 7.2. WAVELLING® Demo software

Our demo software is an application designed to help you get started with our WAVELLING® motor. Its allows to :

- Set angular position control
- Control speed
- Set oscillation control
- Set continuous movement control
- Create and reset index motor origin

Tekceleo can share its demo software code on demand so that you can easily get started on your own development.

## 8. Accessories

### 8.1. Cable matrix

Motor	Connector Housing	Motor cable	Encoder cable
WLG-75-R	2X Molex, Pico-SPOX Female Part No. : 87439-0800  *This connection is delivered with the motor. It is removable.	3X 24 AWG 300 mm for motor cable	5X 24 AWG 300 mm
WLG-75-R AMAG	2X Molex, Pico-SPOX Female Part No. : 87439-0800  *This connection is delivered with the motor. It is removable.	3X 24 AWG 300 mm for motor cable	5X 24 AWG 300 mm
WLG-30-R	JST, SH Connector Housing, 8 Way Part No. : SHR-08V-S-B  *This connection is fixed to the motor. It is not removable.	3X 30 AWG 300 mm	5X AWG 300 mm
WLG-30-R AMAG	JST, SH Connector Housing, 8 Way Part No. : SHR-08V-S-B  *This connection is fixed to the motor. It is not removable.	3X 30 AWG 300 mm	5X AWG 300 mm
WLG-20-R	JST, SH Connector Housing, 8 Way Part No. : SHR-08V-S-B  *This connection is fixed to the motor. It is not removable.	3X 30 AWG 300 mm	5X AWG 300 mm
WLG-20-R AMAG	JST, SH Connector Housing, 8 Way Part No. : SHR-08V-S-B  *This connection is fixed to the motor. It is not removable.	3X 30 AWG 300 mm	5X AWG 300 mm

## 8.2. Electrical cable extensions

Motor	Cable extension length	Feature
WLG-75-R	[2WIRAT0001A00] WLG-75 EXTENSION 5m	Removable extension with 2 PCB ends with connector (Pico-SPOX™ Wire-to-Board Connector 8 Circuits) and mechanical screw connection.  Extension cable is protected by a nylon braid and internal shielding.
WLG-75-R AMAG	[2WIRAT0001A00] WLG-75 EXTENSION 5m	Removable extension with 2 PCB ends with connector (Pico-SPOX™ Wire-to-Board Connector 8 Circuits) and mechanical screw connection.  Extension cable is protected by a nylon braid and internal shielding.
WLG-30-R WLG-30-R AMAG	[2WIRAT0003A02] WLG-30 EXTENSION 1m	Removable extension with 2 PCB ends with connector (SH serie Wire-to-Board Connector 8 Circuits) and mechanical screw connection.
	[2WIRAT0002A02] WLG-30 EXTENSION 5m	Extension cable is protected by a nylon braid and internal shielding.
WLG-20-R WLG-20-R AMAG	[2WIRAT0003A02] WLG-30 EXTENSION 1m	Removable extension with 2 PCB ends with connector (SH serie Wire-to-Board Connector 8 Circuits) and mechanical screw connection.
	[2WIRAT0002A02] WLG-30 EXTENSION 5m	Extension cable is protected by a nylon braid and internal shielding.



**Contact us at :**

[www.tekceleo.com](http://www.tekceleo.com)